

## ÜNİVERSAL TORNA AYNALARI SIKMA KAPASİTELERİ

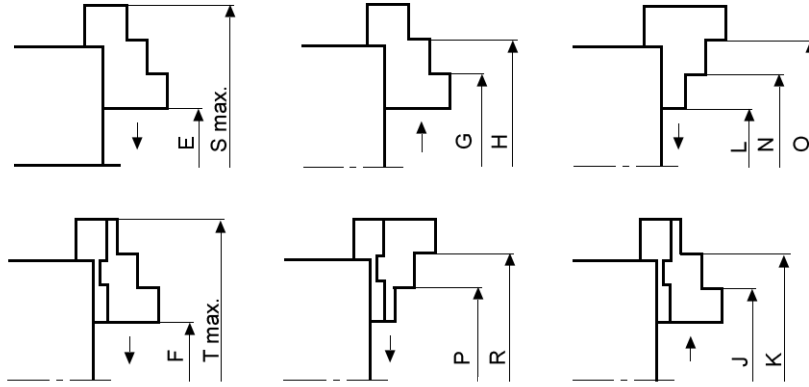

Ø	E	F	G	H	J	K	L	N	O	P	R	S max.	T max.
80	3-27	-	23-48	48-73	-	-	3-27	27-51	52-76	-	-	98	-
100	3-39	3-45	24-60	58-94	25-67	60-102	3-39	30-66	64-100	42-72	77-107	122	130
125	3-49	3-47	30-75	70-116	28-74	69-115	3-49	38-84	83-125	50-95	90-136	152	163
160	3-76	3-76	46-119	87-160	35-108	91-166	3-76	50-123	91-164	51-128	109-185	208	218
200	5-88	5-83	56-140	116-200	46-125	105-185	5-88	57-140	117-200	69-148	127-207	246	254
250	5-107	5-125	68-162	156-250	60-183	124-247	5-107	66-168	154-256	83-206	147-270	314	328
315	8-136	8-131	74-201	188-315	65-193	145-273	8-131	79-207	193-321	99-225	174-305	392	382
400	10-187	10-187	90-268	223-400	105-282	173-350	10-187	92-274	224-406	118-290	189-358	498	454
500	25-250	25-250	135-360	275-500	135-411	201-477	25-250	135-360	275-500	125-447	191-513	626	579

## YUMUŞAK AYAK SIKMA KAPASİTELERİ

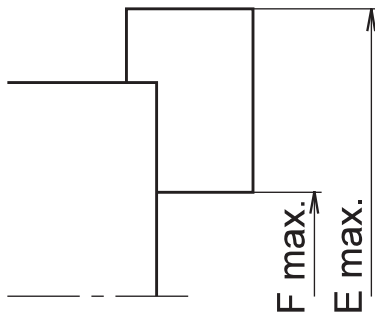

Ø	E max.	F max.
80	98	24
100	122	36
125	152	46
160	208	72
200	246	84
250	314	104
315	392	144
400	498	192
500	626	256

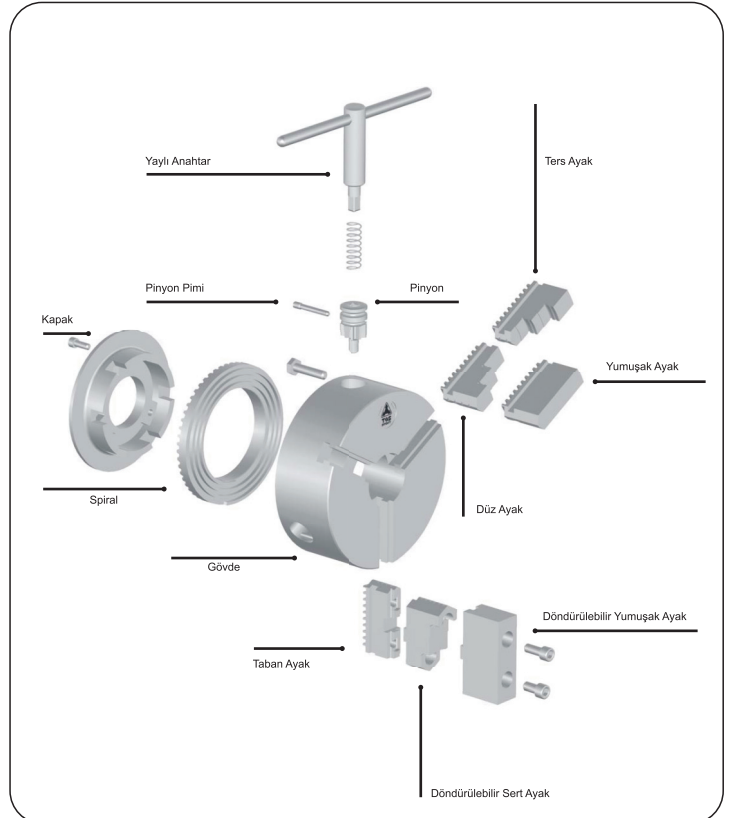

## 3 AYAKLI AYNALAR

## ÖZELLİKLER

- 3 AYAKLI MERKEZİ SIKMALI ÜNİVERSAL TORNA AYNASI
- YÜKSEK KALİTELİ DÖKÜM GÖVDE
- ÜNİVERSAL TORNA TEZGAHLARINDA FENER MİLİNE FLANŞ İLE BAĞLANIR
- FREZELERDE, DİVİZÖRLERDE VE TABLALARDA KULLANILIR

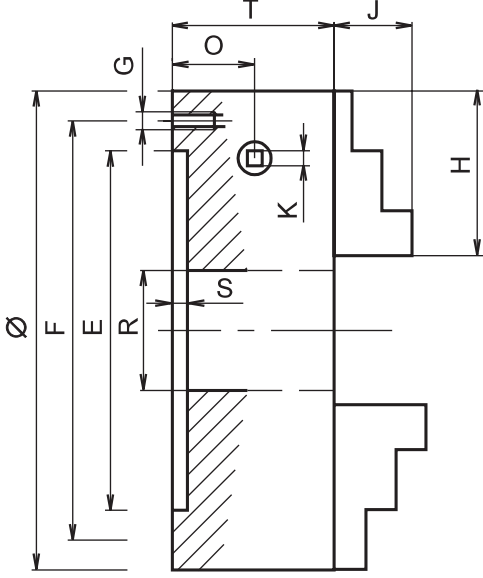

KOD	Ø	E H6	F±0,2	G	H	J	K	O	S	T	R	Kg	max d/d	FİYAT EUR
TOS.IUS.	80	63	70	3×M5	35,5	13	6	16,5	3	45	17	1,20	6000	
TOS.IUS.	100	80	90	3×M6	41,5	17	8	18,0	3	52	23	2,25	5300	
TOS.IUS.	125	100	110	3×M8	51,5	19	8	22,0	4	58	28	3,90	4500	
TOS.IUS.	160	130	143	3×M8	66,0	23	9	22,0	4	62	48	6,70	3500	
TOS.IUS.	200	162	180	3×M10	74,0	29	11	27,5	5	76	52	13,80	3000	
TOS.IUS.	250	210	226	3×M10	97,5	33	12	29,5	5	82	78	21,80	2800	
TOS.IUS.	315	265	290	4×M12	123,0	40	14	35,0	6	100	108	41,60	1800	
TOS.IUS.	400	350	375	6×M12	152,5	50	17	39,0	7	110	144	75,00	1300	
TOS.IUS.	500	420	458	6×M16	188,5	54	17	43,0	8	120	190	140,00	1100	

STANDART AKSESUARLAR	1 TAKIM DÜZ AYAK	1 TAKIM TERS AYAK	1 ADET ANAHTAR	FLANŞ BAĞLAMA CİVATASI	İSTEĞE BAĞLI AKSESUARLAR	1 TAKIM YUMUŞAK AYAK	AYNA BAĞLAMA FLANŞI
							

## 4 AYAKLI AYNALAR

### ÖZELLİKLER

- 4 AYAKLI MERKEZİ SIKMALI ÜNİVERSAL TORNA AYNASI
- YÜKSEK KALİTELİ DÖKÜM GÖVDE
- ÜNİVERSAL TORNA TEZGAHLARINDA FENER MİLİNE FLANŞ İLE BAĞLANIR
- FREZELERDE, DİVİZÖRLERDE VE TABLALARDA KULLANILIR

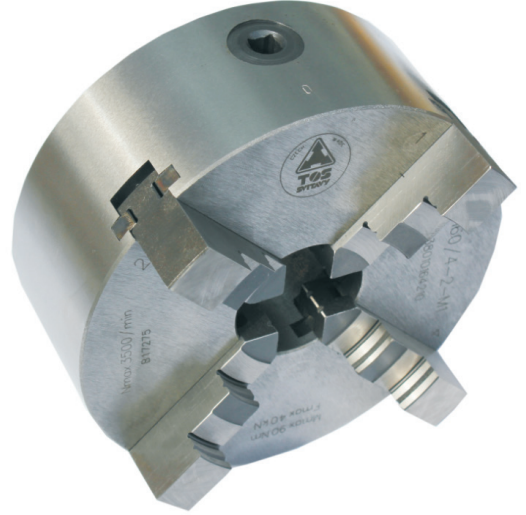
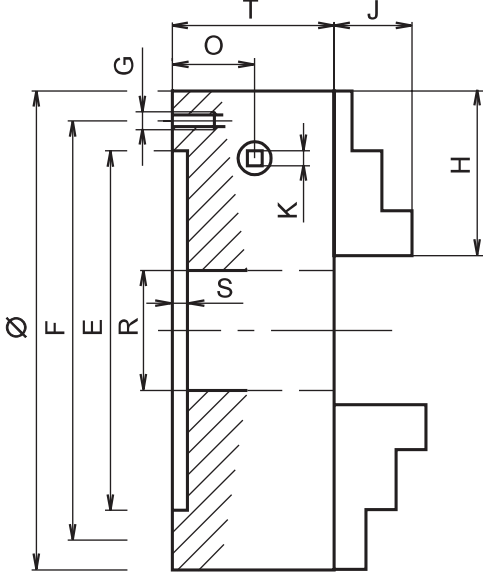

KOD	Ø	E H6	F±0,2	G	H	J	K	O	S	T	R	Kg	max d/d	FİYAT EUR
TOS.IUS.	80	63	70	3×M5	35,5	13	6	16,5	3	45	17	1,25	6000	
TOS.IUS.	100	80	90	3×M6	41,5	17	8	18,0	3	52	23	2,30	5300	
TOS.IUS.	125	100	110	3×M8	51,5	19	8	22,0	4	58	28	4,00	4500	
TOS.IUS.	160	130	143	3×M8	66,0	23	9	22,0	4	62	48	6,80	3500	
TOS.IUS.	200	162	180	3×M10	74,0	29	11	27,5	5	76	52	14,00	3000	
TOS.IUS.	250	210	226	3×M10	97,5	33	12	29,5	5	82	78	22,20	2800	
TOS.IUS.	315	265	290	4×M12	123,0	40	14	35,0	6	100	108	42,50	1800	
TOS.IUS.	400	350	375	6×M12	152,5	50	17	39,0	7	110	144	76,10	1300	
TOS.IUS.	500	420	458	6×M16	188,5	54	17	43,0	8	120	190	142,00	1100	

STANDART AKSESUARLAR	1 TAKIM DÜZ AYAK	1 TAKIM TERS AYAK	1 ADET ANAHTAR	FLANŞ BAĞLAMA CİVATASI	İSTEĞE BAĞLI AKSESUARLAR	1 TAKIM YUMUŞAK AYAK	AYNA BAĞLAMA FLANŞI
							



## KEPENKLİ AYNALAR

## ÖZELLİKLER

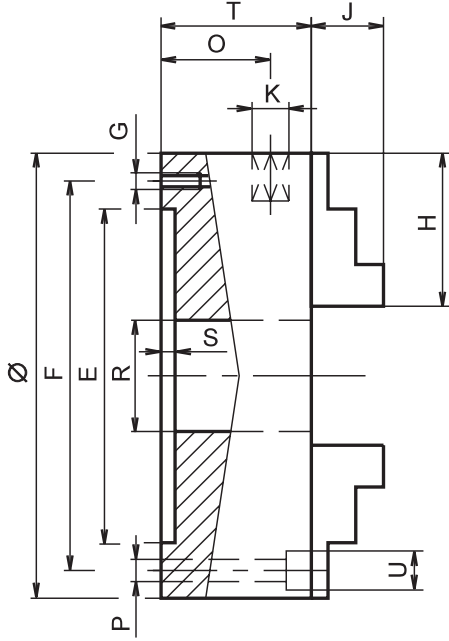
- 4 AYAKLI HER BİR AYAK BAĞIMSIZ OLARAK AYARLANABİLİR
- KARE, ÇOKGEN, DAİRESEL OLAN VEYA OLMAYAN PARÇALARIN İŞLENMESİNDE KULLANILIR
- ÜNİVERSAL TORNA TEZGAHLARINDA FENER MİLİNE FLANŞ İLE BAĞLANIR
- FREZELERDE, DİVİZÖRLERDE VE TABLALARDA KULLANILABİLİR



KOD	Ø	E <sub>h7</sub>	F±0,2	G	H	J	K	O	P	R	S	T	U	Kg	max d/d	FİYAT EUR
TOS.LUD.	85	62	72	—	34	17	6	20	4x7	25	4	42	11	1,60	4800	
TOS.LUD.	100	70	83	—	41	17	6	20	4x9	25	4	42	15	2,75	4200	
TOS.LUD.	125	95	108	—	51	19	8	21	4x9	28	4	44	15	4,85	3700	
TOS.LUD.	160	125	140	4xM10	47	22	8	32	4x11	45	4	54	17	7,32	3000	
TOS.LUD.	200	125	140	4xM10	75	32	12	44	4x11	50	4	72	17	15,42	2300	
TOS.LUD.	250	200	224	4xM12	75	32	12	44	4x13	60	5	72	20	23,80	1700	
TOS.LUD.	315	200	224	4xM12	100	36	14	49	4x13	75	5	80	20	44,50	1500	
TOS.LUD.	350	260	286	—	100	37	14	60	4x13	75	5	91	20	54,10	1300	
TOS.LUD.	400	260	286	—	100	37	14	60	4x13	75	5	91	20	57,50	1300	

STANDART AKSESUARLAR	1 TAKIM AYAK	1 ADET ANAHTAR	FLANŞ BAĞLAMA CIVATASI	İSTEĞE BAĞLI AKSESUARLAR	AYNA BAĞLAMA FLANŞI
					

ÜNİVERSAL TORNA AYNASI DÜZ AYAK TAKIMI
 

---

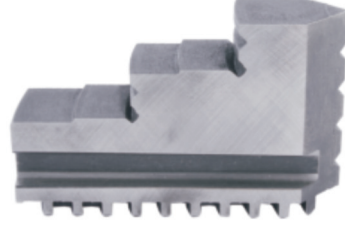
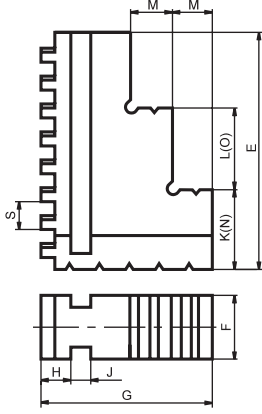

KOD	Ø	E	F	G	H	J	K	L	M	N	O	S	3 AYAKLI SET	4 AYAKLI SET
													FİYAT EUR	FİYAT EUR
TOS.SCV.	80	35,5	10	27	5,9	5	10,5	12,5	6	11,0	12,5	6		
TOS.SCV.	100	41,5	14	34	5,9	7	10,5	7,0	8	11,0	17,0	6		
TOS.SCV.	125	51,5	16	36	5,9	7	13,0	20,5	8	13,5	20,5	6		
TOS.SCV.	160	66,0	18	42	7,4	7	21,5	20,5	10	22,0	20,5	6		
TOS.SCV.	200	74,0	22	54	9,9	8	20,0	36,0	12	16,0	36,0	8		
TOS.SCV.	250	97,5	25	58	9,9	8	22,5	49,0	14	25,0	49,0	8		
TOS.SCV.	315	123,0	32	71	11,9	12	27,5	62,0	16	30,5	62,0	10		
TOS.SCV.	400	152,5	32	86	14,9	12	41,5	66,0	20	43,0	66,0	12		
TOS.SCV.	500	188,5	42	95	17,3	15	55,5	70,0	20	63,0	70,0	12		

 ÜNİVERSAL TORNA AYNASI TERS AYAK TAKIMI
 

---

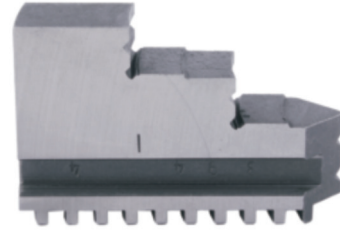
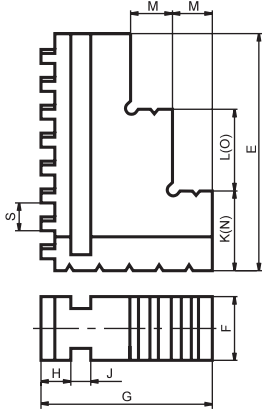

KOD	Ø	E	F	G	H	J	K	L	M	N	S	O	3 AYAKLI SET	4 AYAKLI SET
													FİYAT EUR	FİYAT EUR
TOS.SCN.	80	35,5	10	27	5,9	5	10,5	12,5	6	11,0	6	12,5		
TOS.SCN.	100	41,5	14	34	5,9	7	10,5	7,0	8	11,0	6	17,0		
TOS.SCN.	125	51,5	16	36	5,9	7	13,0	20,5	8	13,5	6	20,5		
TOS.SCN.	160	66,0	18	42	7,4	7	21,5	20,5	10	22,0	6	20,5		
TOS.SCN.	200	74,0	22	54	9,9	8	20,0	36,0	12	16,0	8	36,0		
TOS.SCN.	250	97,5	25	58	9,9	8	22,5	49,0	14	25,0	8	49,0		
TOS.SCN.	315	123,0	32	71	11,9	12	27,5	62,0	16	30,5	10	62,0		
TOS.SCN.	400	152,5	32	86	14,9	12	41,5	66,0	20	43,0	12	66,0		
TOS.SCN.	500	188,5	42	95	17,3	15	55,5	70,0	20	63,0	12	70,0		

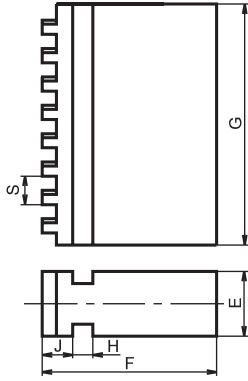
**ÜNİVERSAL TORNA AYNASI YUMUŞAK AYAK TAKIMI**

KOD	Ø	E	F	G	H	J	S	3 AYAKLI SET	4 AYAKLI SET
								FİYAT EUR	FİYAT EUR
TOS.MC.	80	10	27,9	37,2	5	5,9	6		
TOS.MC.	100	14	34,9	43,2	7	5,9	6		
TOS.MC.	125	16	36,9	53,2	7	5,9	6		
TOS.MC.	160	18	43,1	67,9	7	7,4	6		
TOS.MC.	200	22	55,1	75,9	8	9,9	8		
TOS.MC.	250	25	59,1	99,4	8	9,9	8		
TOS.MC.	315	32	72,4	124,0	12	11,9	10		
TOS.MC.	400	32	87,4	153,5	12	14,9	12		
TOS.MC.	500	42	95,0	190,0	15	17,3	12		

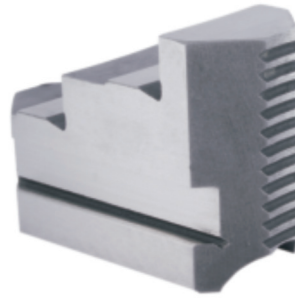
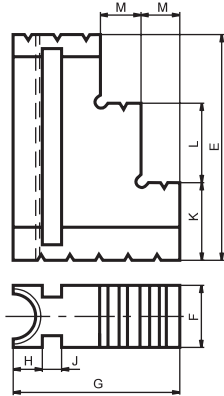
**KEPENKLİ AYNA AYAĞI ( 1 ADET )**

KOD	Ø	E	F	G	H	J	K	L	M	FİYAT EUR
TOS.LC.	85	34	14	34	5,9	7	9	9	8	
TOS.LC.	100	41	14	34	5,9	7	10	12	8	
TOS.LC.	125	51	16	36	5,9	7	10	12	8	
TOS.LC.	160	47	24	39	8,0	10,3	12	12	8	
TOS.LC.	200	75	32	54	11,0	12,3	28	28	12	
TOS.LC.	250	75	32	54	11,0	12,3	28	28	12	
TOS.LC.	315	100	36	63	12,0	15,3	35	35	14	
TOS.LC.	350	100	36	63	12,0	15,3	35	35	14	
TOS.LC.	400	100	36	63	12,0	15,3	35	35	14	

ÜNİVERSAL TORNA AYNA SİRALİ



KOD	Ø	A	FİYAT EUR
TOS.SPR.	80	30	
TOS.SPR.	100	40	
TOS.SPR.	125	50	
TOS.SPR.	160	84	
TOS.SPR.	200	100	
TOS.SPR.	250	132	
TOS.SPR.	315	168	
TOS.SPR.	400	225	
TOS.SPR.	500	270	

ÜNİVERSAL TORNA AYNA ANAHTARI

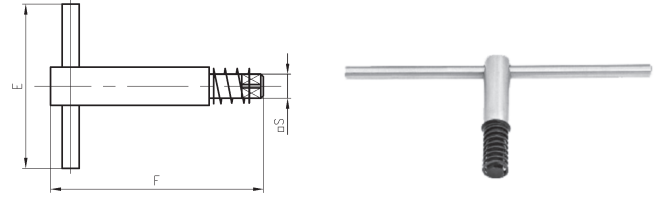

KOD	Ø	E	F	S	FİYAT EUR
TOS.ANH.	80	140	90	6	
TOS.ANH.	100	175	95	6	
TOS.ANH.	125	175	95	8	
TOS.ANH.	160	200	115	9	
TOS.ANH.	200	285	150	11	
TOS.ANH.	250	315	165	12	
TOS.ANH.	315	350	180	14	
TOS.ANH.	400	450	250	17	
TOS.ANH.	500	450	250	17	

ÜNİVERSAL TORNA AYNASI PİNYONU / ADET

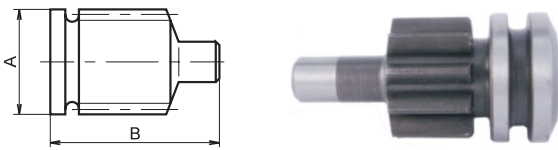

KOD	Ø	A	B	FİYAT EUR
TOS.PNY.	80	20	28,5	
TOS.PNY.	100	22	34	
TOS.PNY.	125	22	43	
TOS.PNY.	160	25	43	
TOS.PNY.	200	27	59	
TOS.PNY.	250	33	66,5	
TOS.PNY.	315	40	84	
TOS.PNY.	400	44	102	
TOS.PNY.	500	44	129	

ÜNİVERSAL TORNA AYNASI PİNYON PİMİ / ADET

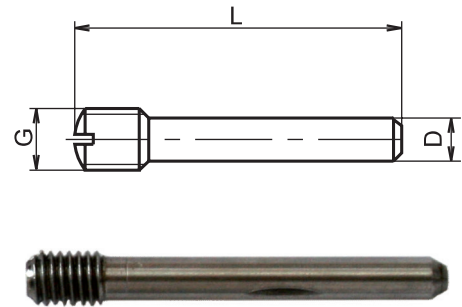

KOD	Ø	G	D	L	FİYAT EUR
TOS.PİM.	80	M5	4,0	34	
TOS.PİM.	100	M5	4,0	34	
TOS.PİM.	125	M6	4,7	40	
TOS.PİM.	160	M6	4,7	40	
TOS.PİM.	200	M6	4,7	40	
TOS.PİM.	250	M6	4,7	45	
TOS.PİM.	315	M8	6,3	60	
TOS.PİM.	400	M10	8,1	66	
TOS.PİM.	500	M10	8,1	66	